



An Autonomy Architecture for High-Density Operations of Small UAS in Low-Altitude Urban Environments

Corey A. Ippolito¹, Kalmanje Krishnakumar²
NASA Ames Research Center, Moffett Field, CA, 94035

Vahram Stepanyan³
University of California Santa Cruz, NASA Ames Research Center, Moffett Field, CA, 94035

Alfredo Bencomo⁴, Anjan Chakrabarty⁵, Josh Baculi⁶
SGT Inc., NASA Ames Research Center, Moffett Field, CA, 94035

Low-altitude flight operations over densely-populated urban centers represent one of the most challenging environments for small Unmanned Aircraft Systems (UAS) in terms of autonomy and control. The challenges become more difficult as the problem scales up to include requirements for interoperability with large-scale high-density UAS traffic system concepts. In this paper, we present the NASA SAFE50 Autonomy Reference Architecture. This architecture has been developed in conjunction with an advanced traffic management design study, that seeks to deliver a validated reference design for advanced intelligent autonomous vehicles operating in a light-weight traffic management system. This paper presents a summary of the requirements derived from the associated study, presents the SAFE50 autonomy architecture, presents the flight vehicle and avionics hardware designs, and presents the flight software architecture. The architecture has been implemented in both simulation and in flight hardware prototyping. This paper presents results from simulation and flight testing towards verification and validation of the reference architecture design.

I. Introduction

Enabling safe, routine, and high-density flight operations of small UAS at low-altitude over heavily populated urban centers presents a difficult challenge for emerging UAS system management concepts. Urban operations by definition involve flight over people, property, and infrastructure. Low-altitude urban environments - such as urban canyons - are one of the most difficult areas for UTM to consider. Mission concepts require routine operations in a cluttered radio-frequency (RF) environment with degraded or denied Global Positioning System (GPS) reception. Flights with any appreciable distance will be beyond visual and communications line-of-sight from ground operators. Timely detection and response to emergencies and onboard failures, which is critical for safe aircraft operation, will be difficult. Without onboard pilots, the requirement to safely address failures - for instance, to quickly scan the external environment and identify safe landing locations in an emergency that is currently free from pedestrians - is difficult in these densely-populated areas. Winds and micro-gusts regularly experienced in urban environments are potentially fatal to small vehicles, and are complex, difficult to predict and detect, and difficult to robustly accommodate. Likewise, stationary objects regularly found in these environments, such as power-lines and cables, are also dangerous and difficult-to-detect. Separation assurance and collision avoidance between air vehicles in a mixed-use airspace - both manned and unmanned - is non-trivial. There are considerable challenges in addressing all stakeholder desires, such as certifiability or insurability. While autonomous systems research for flight vehicles has been an active field for many decades, there is no general agreement on specific requirements for autonomous systems

¹ Aerospace Scientist, NASA Ames Research Center, Moffett Field, CA 94035, AIAA Member.

² NASA Ames Research Center, Moffett Field, CA 94035, AIAA Senior Member.

³ Senior Research Scientist, University of California Santa Cruz. AIAA Senior Member.

⁴ Research Engineer, SGT Inc., Moffett Field, CA 94035.

⁵ Research Engineer, SGT Inc., Moffett Field, CA 94035. AIAA Member.

⁶ Systems Engineer, HX5 LLC., NASA Ames Research Center, Moffett Field, CA 94035, AIAA Member.

operating under a UAS traffic system in urban areas, with many differing competing concepts, definitions, and ideas for autonomy, and a very large possible design space.

This work seeks to establish a feasible reference autonomy architecture for control of vehicles operating in an urban UAS traffic system. This paper presents the SAFE50 autonomy architecture. This architecture has been formulated to meet the requirements for an advanced system design concept study involving larger-scale traffic control. This design places emphasis on intelligent, advanced, highly-autonomous, and highly-capable vehicles. This paper presents a summary of the requirements derived from the associated study, presents the SAFE50 architecture, presents the flight vehicle and avionics hardware designs, then presents the flight software architecture. The architecture has been implemented in both simulation and in flight hardware prototypes. The system is currently undergoing analysis and testing. This paper presents preliminary results from simulation and flight testing towards verification and validation the reference architecture design.

II. Overview

Autonomy can be broadly defined as anything within the look, think, act, and communicate loop for an intelligent system. A conceptual representation of the SAFE50 autonomy reference architecture and the scope of focus for this project is shown in Figure 1. Each vehicle system will require platform-specific subsystems that are certified under the UAS manufacturer's certification processes and are delivered with the vehicle. This includes actuation systems, propulsion systems, and inner-loops for industry standard guidance, navigation, and control (GN&C) systems. For instance, the vehicle may be required to deliver attitude control system modes in the GN&C with certain functional requirements and performance guarantees. The SAFE50 autonomy system does focus on specification of higher-level autonomy and non-standard aviation system components that are required to meet the system design requirements. The autonomy architecture focus includes mission planning, decision making, mission execution, path and trajectory generation, GNSS-free navigation system components, environment mapping, object detection and tracking, and intelligent vehicle health management (IVHM) functions. The SAFE50 autonomy system conceptually draws a box around the higher-level flight control and flight management systems that are vehicle agnostic. Human interfaces, such as flight displays, are required but outside of this study's main focus. Likewise, while this study specifies requirements from communication systems, elaboration of the specifics of the vehicle to multi-vehicle (V2X) architecture is beyond the scope of this study.

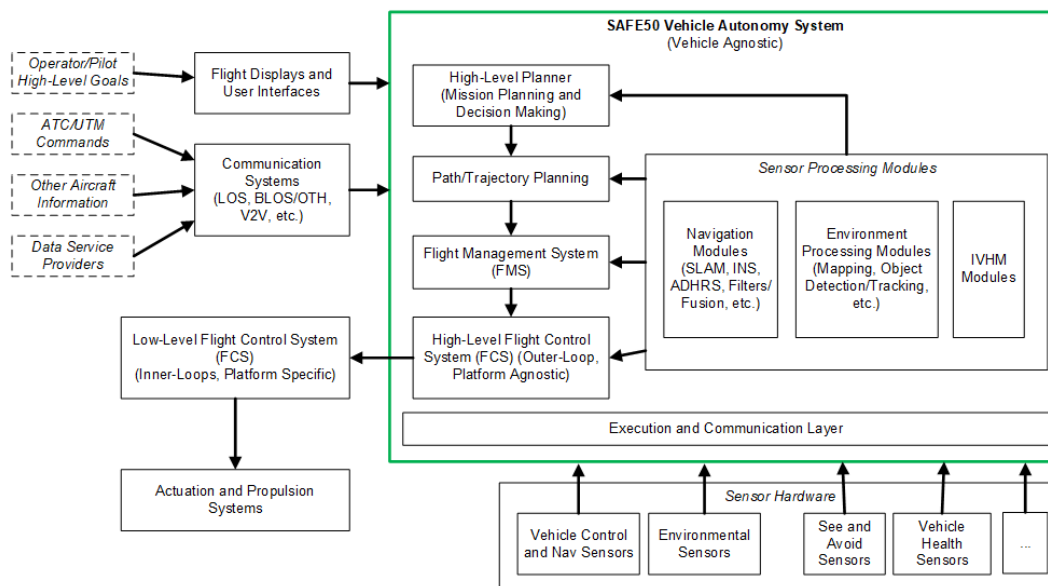

Figure 1. Conceptual View of the SAFE50 Autonomy Reference Architecture

The SAFE50 system design study was developed and presented in [1]. Airspace control concepts were studied in [6]. A conceptual categorization of the requirements for vehicle-level autonomy is summarized in Figure 2. These

include environmental challenges, atmospheric uncertainty, failures and contingencies (including risk models), the UAS vehicle element, ground elements, other aircraft, and objects in the environment.

The UAS is required to continually sense and track dynamic ground objects. The UAS must continuously regenerate plans (nominal, alternative, and contingency plans) from its current state to address any unforeseen static objects that enter the periphery of its sensing range. The planning system frequency requirement is a function of sensing range and parameters such as maximum forward vehicle speed. The UAS must also continuously maintain a safe contingency landing plan for any contingencies that require a ‘land immediately’ type function or an uncontrolled landing (ditch). For each of these contingency plans, the vehicle must maintain its state to ensure the risk to dynamic ground objects is lower than a specified threshold, as specified by a risk model analysis and ground risk mitigation system.

The UAS is required to continuously sense and map static ground objects. The UAS operator is responsible for ensuring ground risks requirements are met based on the ground risk model analysis, manufacturer certification, and manufacturer documentation. Conservative flight plans that always stay away from people/property would satisfy the ground risk requirements, but would not allow access to many areas of the urban space. Alternatively, manufacturers can provide an active ground-risk mitigating flight control system. In the SAFE50 reference design, this system includes dynamic ground object tracking and inputs into a local real-time trajectory planning system. The ground-risk system is responsible for computing sufficient ‘do-not-enter’ volumes that include all positions that would violate minimum safety threshold requirements determined through evaluation of the ground risk model. The local-planner is responsible for ensuring ground-risks ‘do-not-enter’ constraints are not violated. Manufacturers are responsible for providing the trajectory models, cost model parameters such as probability of failure, off-nominal behavioral model, and providing the desired level of contingency management and off-nominal control resilience to meet the specifications of the delivered system. Manufacturers are responsible for V&V and certification of these systems through the appropriate certifying authority stakeholders.

Additional requirements are developed in [1].

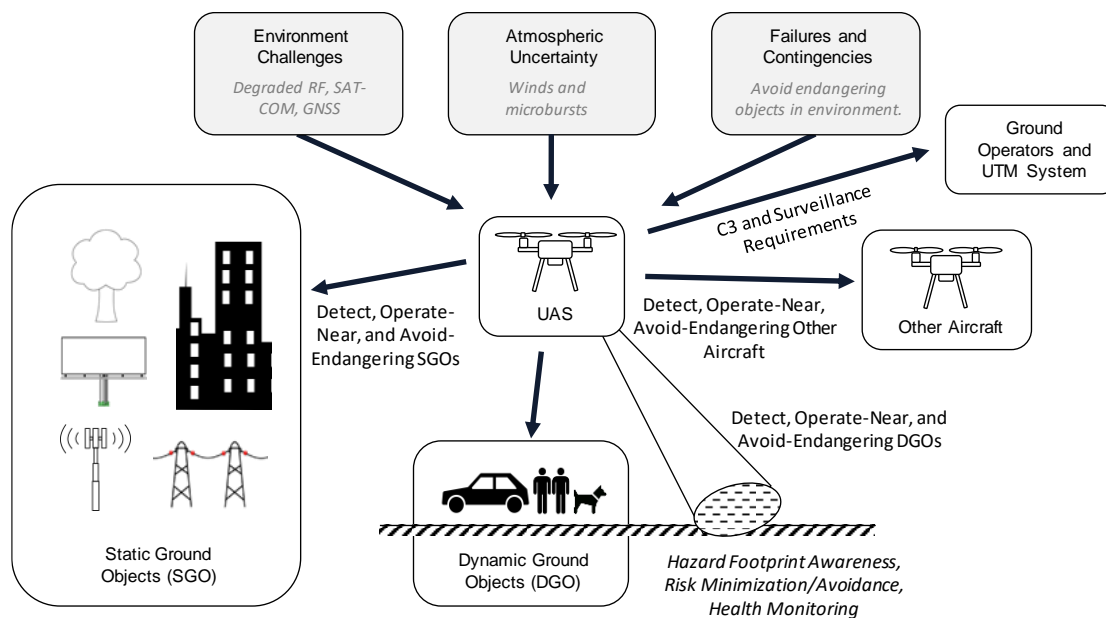

Figure 2. SAFE50 Vehicle-Level Autonomy Requirements

A. SAFE50 System Design Study and Requirements Overview

The top-level (Level 1) system architecture is shown in Figure 3, which represents a slight modification from the existing traffic management architecture developed under the UAS Traffic Management (UTM) project currently at Technical Capability Level (TCL) 3.

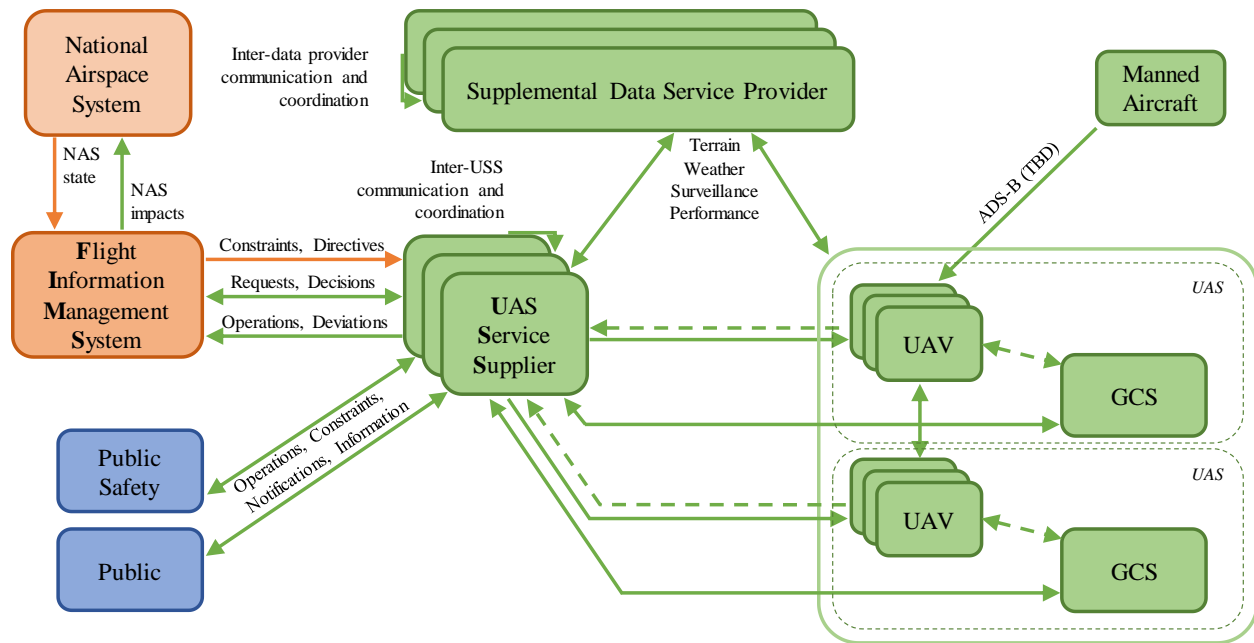

Figure 3. SAFE50 Reference Design - Level 1 System Architecture

In this paper we will focus on the expansion of the UAS systems towards the autonomy system. Here, we refer to the UAS as a level 1 element (1.0). The level 2 elements include the UAS vehicle system (1.1 UAV), and UAS ground control system (1.2 GCS), the UAS operators (1.3), and operational procedures (1.4). These elements are illustrated in Figure 4.

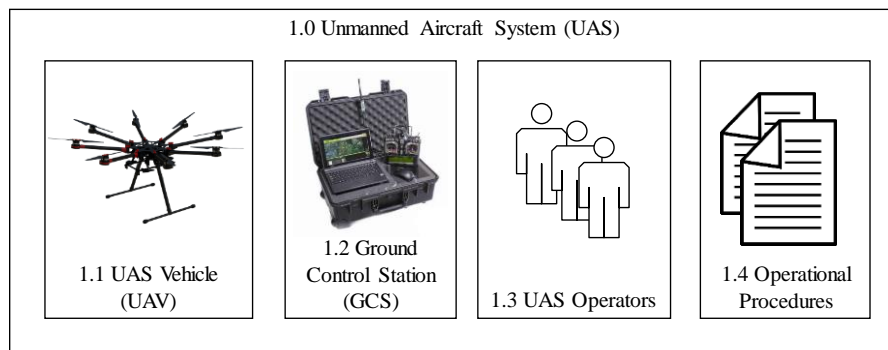

Figure 4. UAS System Architecture

The SAFE50 reference autonomy architecture was developed on a DJI Matrice M600 vehicle platform. This platform provided a number of required features in the SAFE50 vehicle requirements including redundancies in the navigation system, GPS, and batteries, sub-meter GPS accuracy, health monitoring on the battery system and motor systems, and fault-accommodation for failures such as a propeller loss. Specifications for the baseline Matrice are shown in Figure 5.

| | |
|-------------------------------------|--|
| Airframe Make/Model | DJI Matrice 600 Pro |
| Configuration | Hexacopter (6 motors) |
| Length | 1.7 m |
| Height | 0.76 m |
| Weight (Min/Max TOW) | 10.0kg – 15.1kg |
| Payload Weight | 5.5 kg |
| Endurance (@Min/Max TOW) | 40 min - 18 min |
| Battery Specifications | 6 x TB48S Intelligent Flight Battery (6S LiPo) Per: 130W-hr, 0.68 kg Total: 780 W-hr, 4.1 kg |
| Max Service Ceiling Above Sea Level | 2500 m (2170R props) 4500 m (2195R props) |
| Max Wind Resistance | 8 m/s (15.6 kts) |
| Operating Temp Range | -10C to 40C (14F to 104F) |
| Hovering Accuracy (P-GPS) | Vertical: ± 0.5 m, Horizontal: ± 1.5 m |
| Transmitter Frequencies | 5.725 GHz to 5.825 GHz 2.400 GHz to 2.483 GHz 3.1 mi (5 km) Max Range |
| Rev A Components | DJI A3 Pro Autopilot DJI D-RTK DJI Datalink 900 DJI Lightbridge 2 |



DJI Matrice 600 Pro, Stock
Image from <http://www.dji.com>

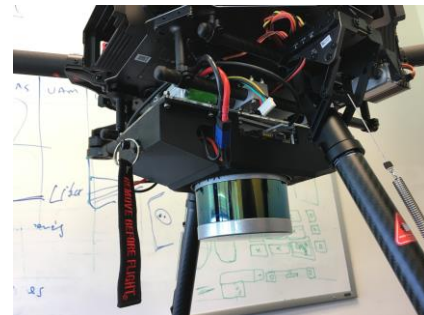

SAFE50 Gen 2 Payload

Figure 5. DJI Matrice 600 Pro Baseline Vehicle.

Specifications (left), without payload (top right), with SAFE50 Gen2 Payload (bottom right). [16]

There are two UAS reference vehicles for SAFE50 testing and validation. The Matrice flight system represents the flight test platform for prototype testing and flight test validation. The SAFE50 simulation UAS reference vehicle is described in [3], and is shown in Figure 6.

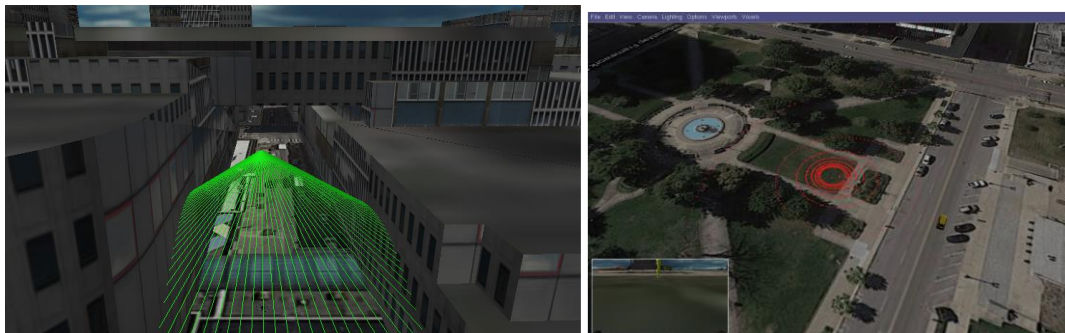

Figure 6. Simulation Modeling and Emulation

Breaking down the 1.2 GCS element, the ground station design is shown in Figure 7. Since this reference vehicle design is our flight test vehicle, this design has a secondary ground station for a payload operator.

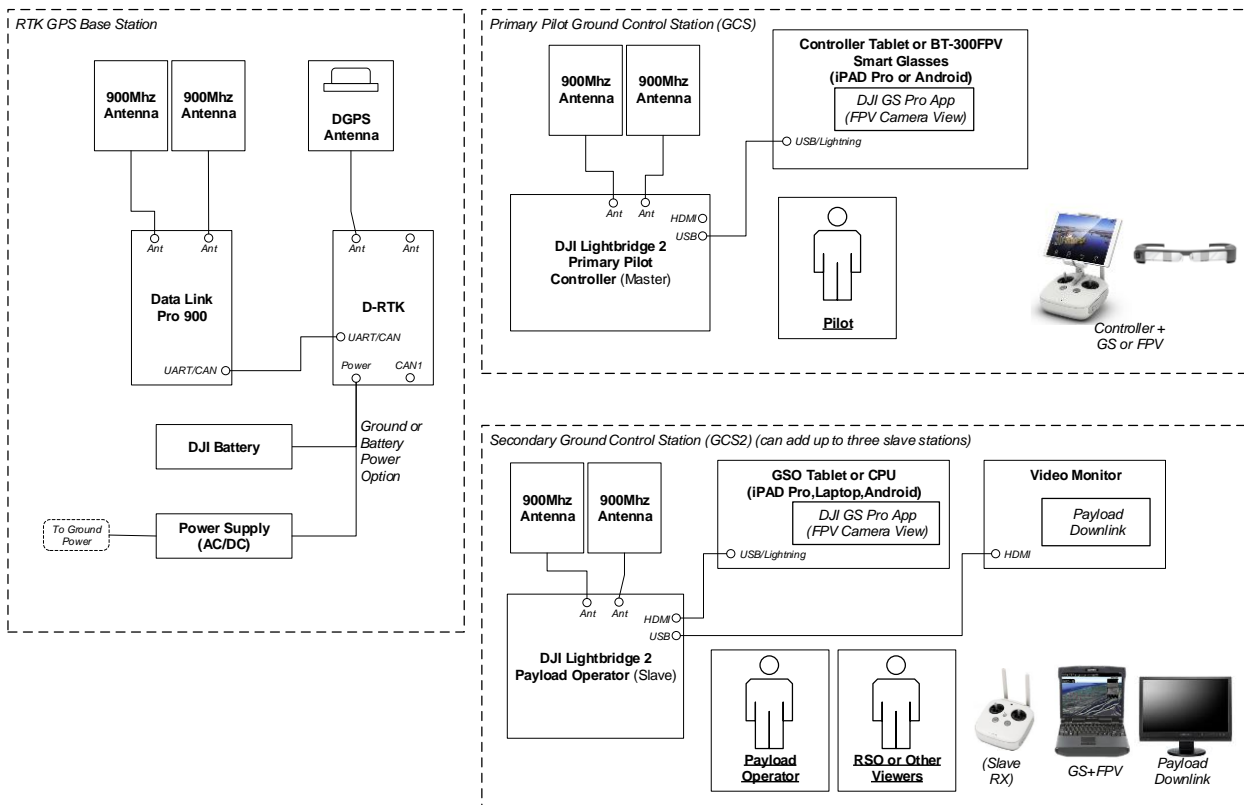

Figure 7. Ground Station Architecture . Images from [16]

The hardware UAS flight vehicle system architecture is shown in in Figure 8.

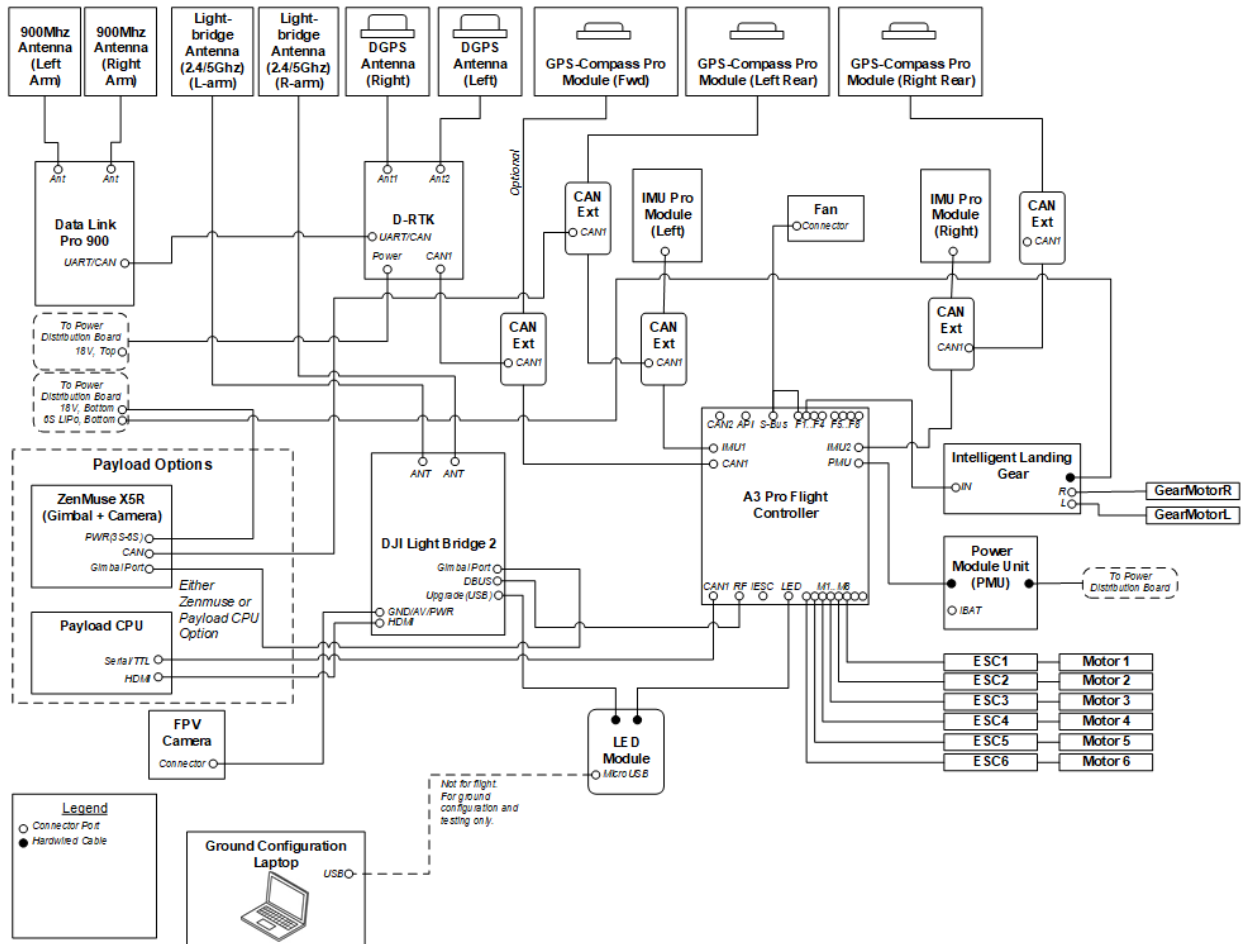

Figure 8. UAS Flight Vehicle Architecture.

B. Autonomy Architecture

The software autonomy architecture is shown in Figure 9 below. In this diagram, timing rate groups are shown in blue. Each block represents an individually controlled software module. This section describes some of the major modules and refers to related publications that provide more detail on these systems.

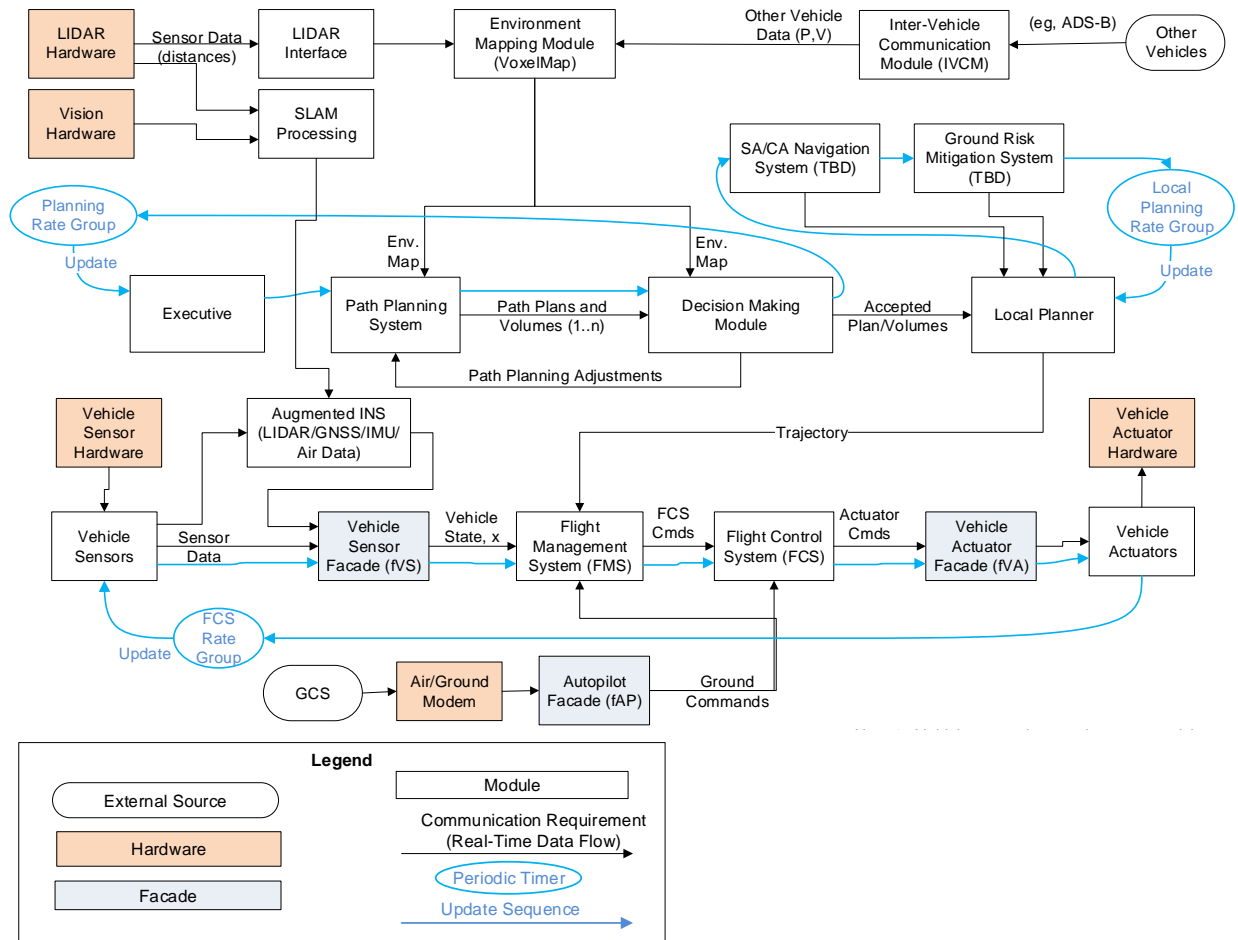

Figure 9. SAFE50 Autonomy Software Block Diagram

1. Decision-Making for Nominal and Off-Nominal Scenarios (Contingency Management)

The Decision Making Module (DMM) has a deterministic component and a probabilistic component. The software configuration diagram is shown in Figure 10.

For implementation of the SAFE50 architecture concept of operations and simulation of scenarios, a high-level DMM module is currently being developed to control execution and meet the function requirements for each nominal and contingency scenario. The deterministic DMM module component design is presented in [13].

The probabilistic DMM component utilizes probabilistic methods to evaluate, select, and adjust proposed trajectories. The DMM is responsible for taking a set of possible trajectories generated by the path planning system, evaluating, and returning a single acceptable trajectory to the Flight Management System (FMS). The DMM is also responsible for controlling the trajectory generation modules within the path planning system; the DMM can adjust the parameters for trajectory generation (e.g., costs, constraints, objectives, initial/final conditions, etc.) based on its analysis. The DMM will evaluate trajectories based on a number of factors which may include: various aspects of safety, power consumption, environmental conditions and winds, and feasibility assessment of proposed trajectories. The DMM may be composed of various sub-modules to help evaluate trajectories, including a dynamic object tracking/estimation module, a power module, etc. [10]

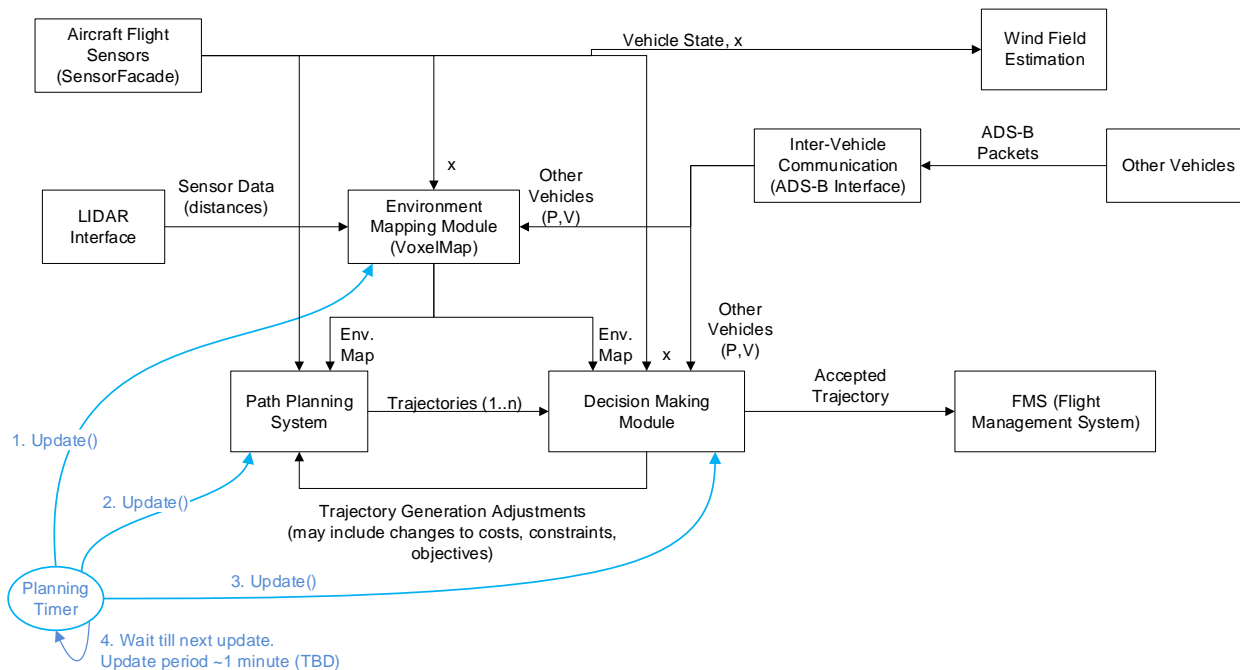

Figure 10. Decision Making Module Architecture

2. Onboard Decentralized CA/SA and Vehicle to Multi-Vehicle (V2X) Communication

The architecture features a cooperative strategy for separation assurance and collision avoidance. This system is documented in [15].

3. Dynamic Ground Risk Mitigation (Onboard Detection and Control)

Ground risk management utilizes an active system for detection and classification of ground objects, and an active system to control trajectories. The dynamic ground-risk mitigation system is conceptually shown in Figure 11. The ground mitigation system takes sensor input and processes the data to identify dynamic ground objects. The location of objects is utilized in a back-propagating trajectory model with a ground-risk model cost function to compute ‘do-not-enter’ volumes. These volumes are passed as constraints to the local planner. The system is described here [4].

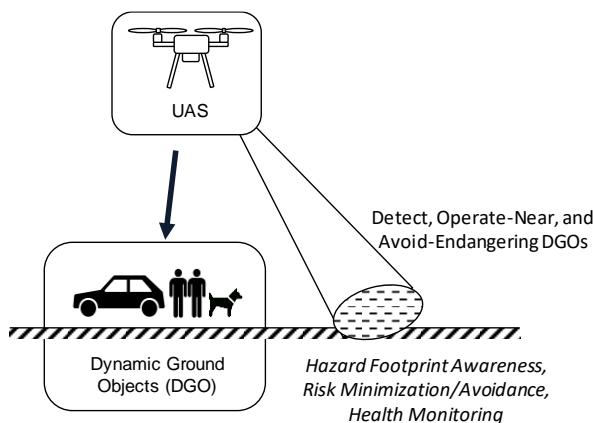

Figure 11. General Requirements for Dynamic Ground Risk Mitigation

4. Flight Management System and Flight Control System

The flight control system and flight management system are described in [3]

5. Resilient Trajectory-Based Control

Resilient flight control research under SAFE50 is available here [8][9][14].

6. Trajectory Planning

The trajectory planning system is documented here. [12]

7. Static Ground Object Detection and Avoidance

Power-lines represent a significant hazard in urban environments. A SAFE50 study was conducted to investigate power-line detection through machine learning and artificial intelligence methods [11] and illustrated in Figure 12.

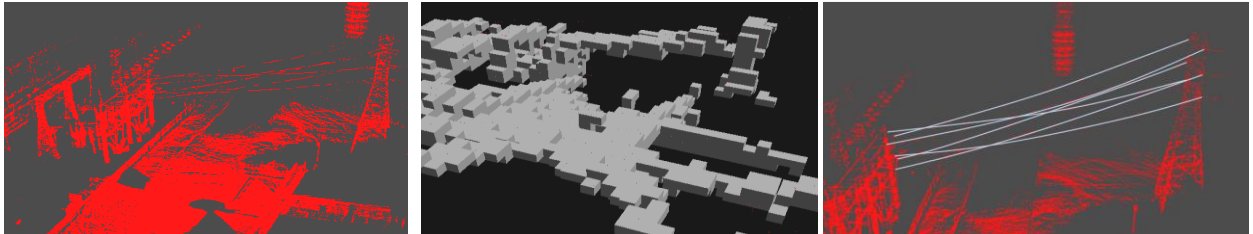

Figure 12. Real-time Power-Line Detection and Reconstruction

The real-time environment map is processed for higher-level planning. A baseline simple A* planner was implemented for validation of the prototype that meets the specified requirements. A voxel-based processing algorithm was developed for fusing sensor data into a common map for obstacle avoidance. A description of this system is provided in [3] and illustrated in Figure 13.

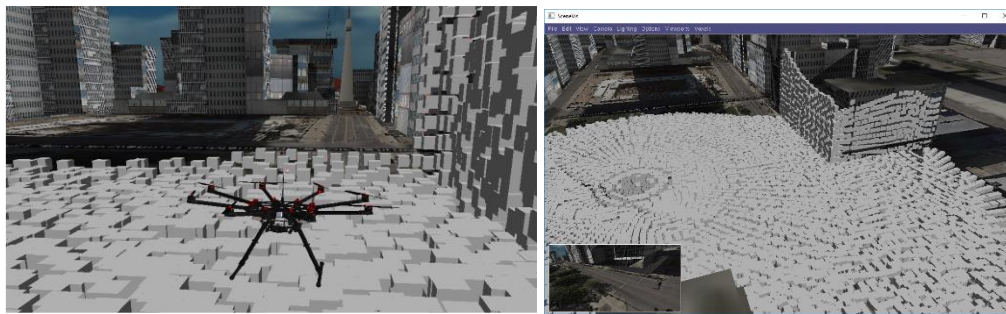

Figure 13. Environment Voxel Map

8. LIDAR-SLAM for GPS-Free Navigation

The architecture features GPS-free navigation utilizing LIDAR input and SLAM (Simultaneous Localization and Mapping), with inputs into an augmented INS filter. Flight test experiments were performed with the system, as described in [5] and illustrated in Figure 14.

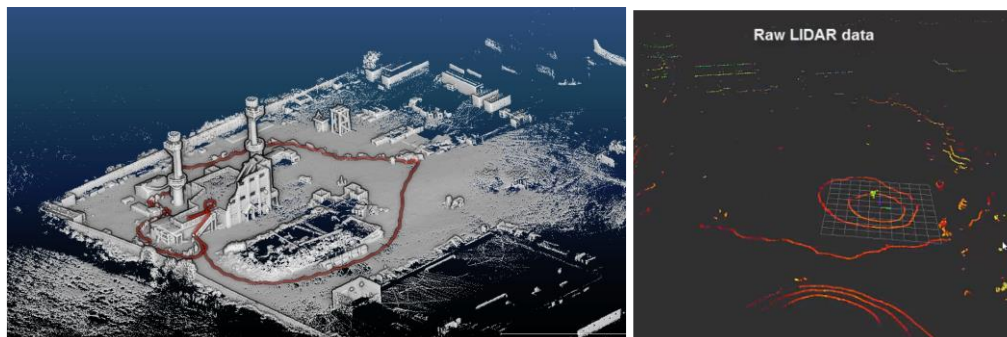
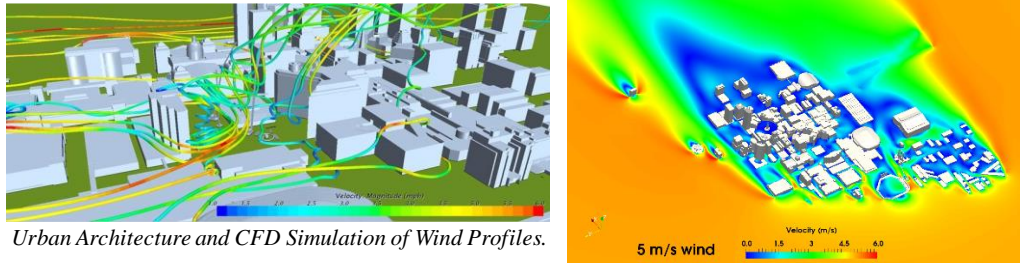

Figure 14. Flight Experiments of GNSS/GPS Free Navigation through LIDAR-based SLAM [5]

9. Urban Wind Field Modeling and Real-Time Estimation

A SAFE50 study was been performed on wind fields over urban environments. This is described in [1]. Additional research was performed to improve modeling of small UAS in winds [3]. A related UTM-funded project provided additional trajectory models [7]. This is illustrated in Figure 15.



Urban Architecture and CFD Simulation of Wind Profiles.

Figure 15. Urban CFD Wind Profiles

An online wind estimation module was added to the system to help estimate the wind field vector from onboard vehicle sensors with an adaptive estimator, as illustrated in Figure 16 [8].

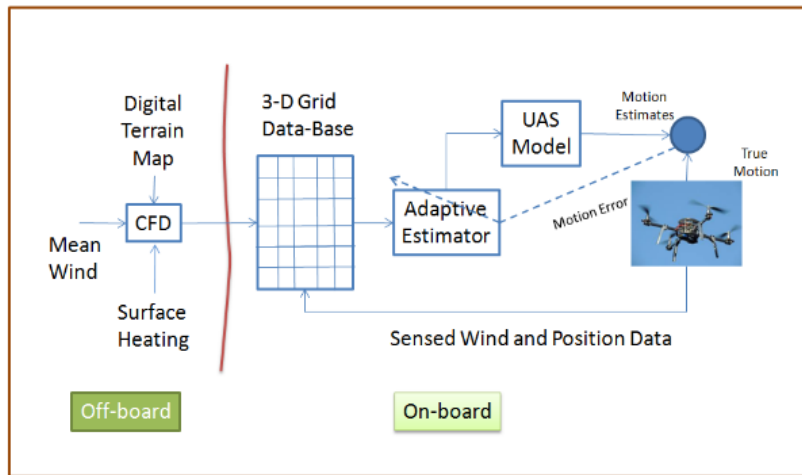

Figure 16. Online Wind Estimation

Acknowledgments

The authors would like to thank our collaborators and colleagues in the NASA UAS Traffic Management (UTM) project and the NASA SAFE50 project team.

References

- [1] Krishnakumar, K. S., Kopardekar, P. H., Ippolito, C. A., Melton, J., Stepanyan, V., Sankararaman, S., & Nikaido, B. (2017). Safe Autonomous Flight Environment (SAFE50) for the Notional Last “50 ft” of Operation of “55 lb” Class of UAS. In AIAA Information Systems-AIAA Infotech@ Aerospace (p. 0445).
- [2] Ippolito, C. A.; Krishnakumar, K.; Stepanyan, V.; Chakrabarty A.; Baculi, J. (2019). SAFE50 Reference Design Study for Large-Scale High-Density Low-Altitude UAS Operations in Urban Areas. In 2019 AIAA Modeling and Simulation Technologies Conference. San Diego, CA. Jan 2109.
- [3] Ippolito, C. A., Hening, S., Sankararaman, S., & Stepanyan, V. (2018). A Modeling, Simulation and Control Framework for Small Unmanned Multicopter Platforms in Urban Environments. In 2018 AIAA Modeling and Simulation Technologies Conference (p. 1915).
- [4] Ippolito, C. A.; Dynamic Ground-Risk Mitigating Flight Control for Autonomous Small UAS in Urban Environments. In 2019 AIAA Modeling and Simulation Technologies Conference. San Diego, CA. Jan 2109.
- [5] Hening, S., Ippolito, C. A., Krishnakumar, K. S., Stepanyan, V., & Teodorescu, M. (2017). 3D LiDAR SLAM Integration with GPS/INS for UAVs in Urban GPS-Degraded Environments. In AIAA Information Systems-AIAA Infotech@ Aerospace (p. 0448).
- [6] Jang, D. S., Ippolito, C. A., Sankararaman, S., & Stepanyan, V. (2017). Concepts of airspace structures and system analysis for uas traffic flows for urban areas. In AIAA Information Systems-AIAA Infotech@ Aerospace (p. 0449).
- [7] Ren, L., Castillo-Effen, M., Yu, H., Yoon, Y., Nakamura, T., Johnson, E. N., & Ippolito, C. A. (2017). Small unmanned aircraft system (sUAS) trajectory modeling in support of UAS traffic management (UTM). In 17th AIAA Aviation Technology, Integration, and Operations Conference (p. 4268).
- [8] Stepanyan, V., & Krishnakumar, K. S. (2017). Estimation, navigation and control of multi-rotor drones in an urban wind field. In AIAA Information Systems-AIAA Infotech@ Aerospace (p. 0670).
- [9] Stepanyan, V., Krishnakumar, K.S. and Bencomo, A., 2016. Identification and reconfigurable control of impaired multi-rotor drones. In AIAA Guidance, Navigation, and Control Conference (p. 1384).
- [10] Sankararaman, S. (2017). Towards a computational framework for autonomous decision-making in unmanned aerial vehicles. In AIAA Information Systems-AIAA Infotech@ Aerospace (p. 0446).
- [11] Ippolito, C., Krishnakumar, K., & Hening, S. (2016). Preliminary results of powerline reconstruction from airborne LiDAR for safe autonomous low-altitude urban operations of small UAS. In IEEE SENSORS, October 2016 (pp. 1-3). IEEE.
- [12] Chakrabarty A.; Ippolito, C. Real-Time Path Planning for Multi-copters flying in UTM-TCL4. In 2019 AIAA Modeling and Simulation Technologies Conference. San Diego, CA. Jan 2109.
- [13] Baculi, J.; Ippolito, C. Onboard Decision-Making for Nominal and Contingency UAV Flight. In 2019 AIAA Modeling and Simulation Technologies Conference. San Diego, CA. Jan 2109.
- [14] Stepanyan, V.; Krishnakumar, K. S. Input Constrained M-MRAC for Multirotors Operating in an Urban Environment. In 2019 AIAA Modeling and Simulation Technologies Conference. San Diego, CA. Jan 2109.
- [15] Chakrabarty A.; Hening, S.; Ippolito, C. Real Time Collision avoidance for UAVs and Vehicle to vehicle (V2V) and vehicle to infrastructure (V2X) communications requirements. In 2019 AIAA Modeling and Simulation Technologies Conference. San Diego, CA. Jan 2109.
- [16] DJI Matrice 600 Pro Product Website. <https://www.dji.com/matrice600-pro>. [retrieved 1 Dec 2018]